



# PUMP "K" (compact)

## 1,2 Liters

CENTRALIZED LUBRICATION SYSTEM



OPERATION AND MAINTENANCE MANUAL

Index

<b><u>PART 1 - GENERAL CONSIDERATIONS</u></b> .....	<b>3</b>
<b>OVERVIEW OF THE COMPANY</b> .....	<b>3</b>
<b>MANUFACTURER'S DATA</b> .....	<b>3</b>
<b>CUSTOMER SERVICE</b> .....	<b>3</b>
<b>GENERAL WARNINGS</b> .....	<b>4</b>
<b>SYMBOL LEGEND</b> .....	<b>4</b>
<b>SCOPE OF THIS MANUAL</b> .....	<b>4</b>
<b>HANDBOOK STRUCTURE</b> .....	<b>5</b>
<b>SAFETY STANDARDS APPLIED</b> .....	<b>5</b>
<b>EC DECLARATION OF CONFORMITY</b> .....	<b>6</b>
<b>1.1.0) RECOMMENDED USE</b> .....	<b>7</b>
<b>1.2.0) SAFETY</b> .....	<b>8</b>
<b>1.3.0) DESCRIPTION OF THE SYSTEM</b> .....	<b>8</b>
<b>1.4.0) TECHNICAL SPECIFICATIONS</b> .....	<b>9</b>
<b>1.4.1) ELECTROPUMP</b> .....	<b>9</b>
<b>1.4.2) TIMER</b> .....	<b>13</b>
• PAUSE-OPERATION CYCLE .....	<b>13</b>
<b><u>1.5.0) STORAGE</u></b> .....	<b>14</b>
<b><u>1.6.0) ASSEMBLY</u></b> .....	<b>15</b>
<b><u>1.6.1) OPERATING PROCEDURE</u></b> .....	<b>15</b>
• ELECTROPUMP .....	<b>16</b>
• PUMPING ELEMENT.....	<b>17</b>
• FITTINGS .....	<b>17</b>
• DISTRIBUTOR.....	<b>18</b>
• MAIN LINE AND SECONDARY LINE.....	<b>18</b>
• 12/24 V DC ELECTRICAL CONNECTION .....	<b>19</b>
• VERSION WITHOUT OR TIMER.....	<b>19</b>
<b>1.6.2) WIRING DIAGRAM VERSION 12 / 24 V DC</b> .....	<b>19</b>
• VERSION WITH TIMER PAUSE/OPERATION .....	<b>19</b>
<b><u>PART 2 – OPERATING MANUAL</u></b> .....	<b>20</b>
<b>2.1.0) COMANDS</b> .....	<b>20</b>
<b>2.2.0) TIMER PROGRAMMING</b> .....	<b>21</b>
<b>2.3.0) TANK FILLING</b> .....	<b>23</b>
<b>2.3.1) LUBRICANTS</b> .....	<b>23</b>
<b>2.4.0) START-UP</b> .....	<b>24</b>

---

<b>2.4.1) OPERATING PROCEDURE.....</b>	<b>24</b>
<b><u>PART 3 – MAINTENANCE INSTRUCTION.....</u></b>	<b>25</b>
<b><u>3.1.0) MAINTENANCE INSTRUCTION.....</u></b>	<b>25</b>
<b><u>3.2.0) SCHEDULED MAINTENANCE.....</u></b>	<b>25</b>
<b><u>3.3.0) ANOMALIES.....</u></b>	<b>26</b>
<b><u>PART 4 – SPARE PARTS.....</u></b>	<b>28</b>

---

*PART 1 - GENERAL CONSIDERATIONS**OVERVIEW OF THE COMPANY*

**CIAPONI LUBRIFICAZIONE CENTRALIZZATA S.r.l.** is specialized in the design, manufacture and installation of centralized lubrication points. The company, which initially produced industrial vehicles only, has developed in the years, thanks to the vast experience acquired, earth moving machines and machinery for industrial applications.

Its dynamism has led it to upgrade its engineering, manufacturing and quality control systems with state-of-the-art solutions.

The Quality Control System adopted by the company was certified, in 2001, as compliant with the requirements of standard UNI EN ISO 9001 by the certification body named Det Norske Veritas Italia S.r.l..

The company's mission is supplying its customers with full assistance, from the supply, installation of dependable products down to on-site maintenance.

**CIAPONI LUBRIFICAZIONE CENTRALIZZATA S.r.l.**, is a leading Italian company, with over 35 years of experience that has gradually expanded its market and now serves several European customers.

*MANUFACTURER'S DATA*

Name	-	<b>CIAPONI LUBRIFICAZIONE CENTRALIZZATA S.r.l.</b>
Address	-	Via Guerrazzi, 113 – San Miniato Basso 56028 – Pisa ITALY
Telephone	-	+39 0571 42661
Fax	-	+39 0571 42244
Web site	-	<a href="http://www.ciaponilube.com">www.ciaponilube.com</a>
e-mail address	-	<a href="mailto:export@ciaponilube.com">export@ciaponilube.com</a>
Tax-payer code/VAT no.	-	IT01160480503

*CUSTOMER SERVICE*

**CIAPONI LUBRIFICAZIONE CENTRALIZZATA S.r.l.** follows its customer directly by means of its post-sale servicing.

To request further information or order spare parts, it is possible to contact the **Customer Service** at the phone/fax numbers listed above.

---

## GENERAL WARNINGS

© **All rights reserved.** First edition, January 2025.

This Maintenance and Operation Manual has been prepared by **CIAPONI LUBRIFICAZIONE CENTRALIZZATA s.r.l.** and is supplied as is.

Therefore, it cannot be copied, reproduced, circulated or transcribed, in whole or in part, without the written authorization of **CIAPONI LUBRIFICAZIONE CENTRALIZZATA s.r.l.**

The Manufacturer may change the content of this manual at any time, without warning, for technical or commercial reasons or to comply with new standards or laws.

## SYMBOL LEGEND

### Key to symbols for the correct text interpretation

The symbols listed will be reported to the left of the text or in the vicinity of contents to which the reader should pay attention.



Prohibition signal: it prohibits an action that could cause a hazard.



Prescription signal: it prescribes specific behavior.



Warning signal: it warns of a risk or generic danger.



Electrical warning signal: it warns of a risk or danger of contact with electrical parts.





Education signal: it feels you follow the instructions on the side.

## SCOPE OF THIS MANUAL

This manual supplies the user with all the information required to install, use, service and dismantle the system.

**CIAPONI LUBRIFICAZIONE CENTRALIZZATA s.r.l.** shall not be responsible for damages or faults caused by the failure to comply with the warnings and instructions provided below.

It is therefore advisable to:

-  Carefully read all the parts of the Operation and Maintenance Manual.
-  Keep a copy of the manual in a safe place and always make it available to all operators working with it.

---

## HANDBOOK STRUCTURE

The Complete Handbook is composed of the following parts.

### Part 1 – General aspect

Consists of all the information of product presentation, describing the purpose and scope, the technical characteristics of the main components and the different versions, as well as the directions for the correct installation of centralized lubrication.

### Part 2 – User Manual

Consists of all the general information is the entire set of information necessary for the operation of the plant and for correct control and use of the same.

### Part 3 – Instruction for maintenance

Consists of all the information needed to adequately perform some simple maintenance. In this part there are also some very useful information in the event of a malfunction.

### Part 4 – Spare parts

Consists of all the information necessary for the management of spare parts.

## SAFETY STANDARDS APPLIED

Centralized lubrication systems are designed, manufactured, and installed in accordance with the requirements of **Directive 2006/42/EC (Machinery Directive)**.

Therefore, for the purposes of **CE marking**, the **nameplate** (shown in Figure 1) is affixed to the unit using adhesive and consists of a metal plate (see Figure 2) containing the following information:



Figure 2

The nameplate contains the following information:

- Manufacturer's details Model
- Type Serial number
- Year of manufacture
- Power supply data



Figure 1

Example of a nameplate for a **pump model Euro 3, type 50001, power supply 24 V DC, serial number No. 074237, and production batch January 2025 (month/year)**.

---

## EC Declaration of Conformity

**Manufacturer:** CIAPONI LUBRIFICAZIONE CENTRALIZZATA S.r.l.

**Address:** Via Guerrazzi, 113

56028 San Miniato Basso (PI) – Italy

Telephone: +39 0571 42661

Fax: +39 0571 42244

Website: [www.ciaponilube.com](http://www.ciaponilube.com)

E-mail: [export@ciaponilube.com](mailto:export@ciaponilube.com)

VAT No.: IT01160480503

The manufacturer hereby declares that the machinery:

**Model:** Electric pump

**Type:** K

is in conformity with:

- Directive 2006/42/EC (Machinery Directive), Annex II, Part A;
- Directive 2014/30/EU (EMC Directive);
- Directive 2014/35/EU (Low Voltage Directive).

The manufacturer further declares that conformity has been assessed with reference to the following standards:

- EN 61000-6-4
- EN 61000-6-2
- EN 61000-3-2
- EN 61000-3-3
- EN 60204-1
- EN 50178



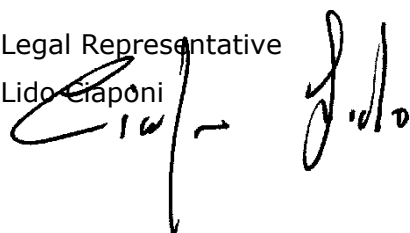

Place and date of issue: San Miniato Basso, August 2018

Legal Representative

Lido Ciaponi



It is important to note that the safe operation and conformity of the system are ensured only if the following conditions are met:

-  • The indications, safety warnings and instructions provided in the operation and maintenance manual are strictly observed.
-  • The system is used in accordance with the instructions provided by the manufacturer.
-  • Adjustment operations are carried out by authorized, trained and qualified personnel.
-  • Maintenance operations are carried out by qualified and authorized technicians.





Failure to comply with the above requirements may result in improper use of the product and may void the manufacturer's warranty.

#### *1.1.0) RECOMMENDED USE*

Centralized lubrication systems are designed to automatically lubricate identified points subject to wear.

Therefore, the system must be used exclusively for the lubrication of the points to which it is connected.



Users are not allowed to apply unauthorized changes to an installed system. Any modification must be carried out by, or expressly authorized by, the manufacturer.

-  • Users are not allowed to apply unauthorized changes to an installed system. Any modification must be carried out by, or expressly authorized by, the manufacturer.
-  • The system shall always be used within the operating parameters specified in paragraph **1.4.0) TECHNICAL SPECIFICATIONS**.
-  • The system must be used only with the lubricants listed in paragraph **2.3.1) LUBRICANTS**.
-  • The Technical Department of **CIAPONI LUBRIFICAZIONE CENTRALIZZATA s.r.l.** can be contacted for further information or feasibility studies.

The manufacturer shall not be held responsible for damages resulting from improper use of the system, or from unauthorized modifications to the system or its components.

Furthermore, the manufacturer shall not be held responsible for damages resulting from the use of non-original spare parts, parts not approved by the manufacturer, or lubricants other than those listed.

### 1.2.0) SAFETY

-  • Improper use of the centralized lubrication system may cause damage due to excessive or insufficient lubrication of the points to which it is connected.
-  • It is always necessary to comply with the accident prevention and environmental regulations in force in the country where the centralized lubrication system is used.

### 1.3.0) DESCRIPTION OF THE SYSTEM

Figure 3 shows a schematic of the centralized lubrication system in its basic configuration. The system comprises the following units:

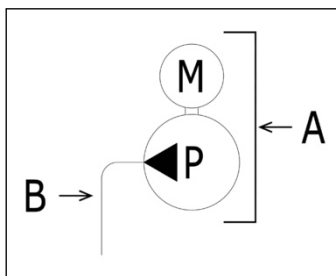

**A – Electro-pump with tank**

**B – Main pipe**

Centralized lubrication systems significantly reduce the maintenance costs of the equipment on which they are installed, lowering downtime for maintenance operations and increasing the life of lubricated components.

Figure 3

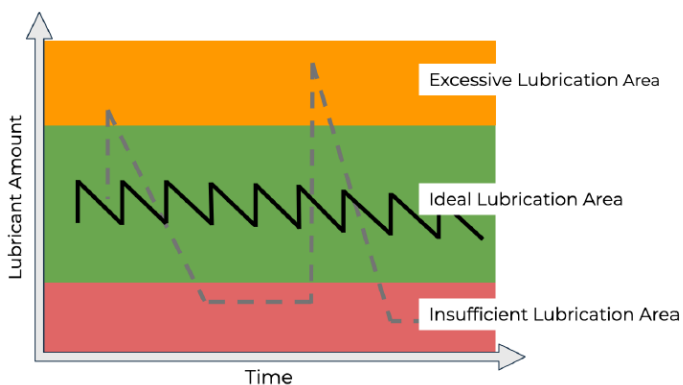

— Automatic Lubrication  
 - - - Manual Lubrication

Figure 4

These systems lubricate all required points, including those not accessible to the operator. When activated, the electric pump delivers lubricant through the main line from the pumping element to the lubrication points. Figure 4 shows the operating cycle of the centralized lubrication system. The system can operate in manual or automatic mode, either controlled by the host machine or by a timer integrated in the pump.

Each system is identified by a serial number stamped on the CE label, under "Serial Number / Year of Manufacture".

-  • The system serial number must always be stated when requesting technical assistance or ordering spare parts.

### 1.4.0) TECHNICAL SPECIFICATIONS

The paragraphs that follow list the technical specifications of each component of the system.

#### 1.4.1) ELECTROPUMP

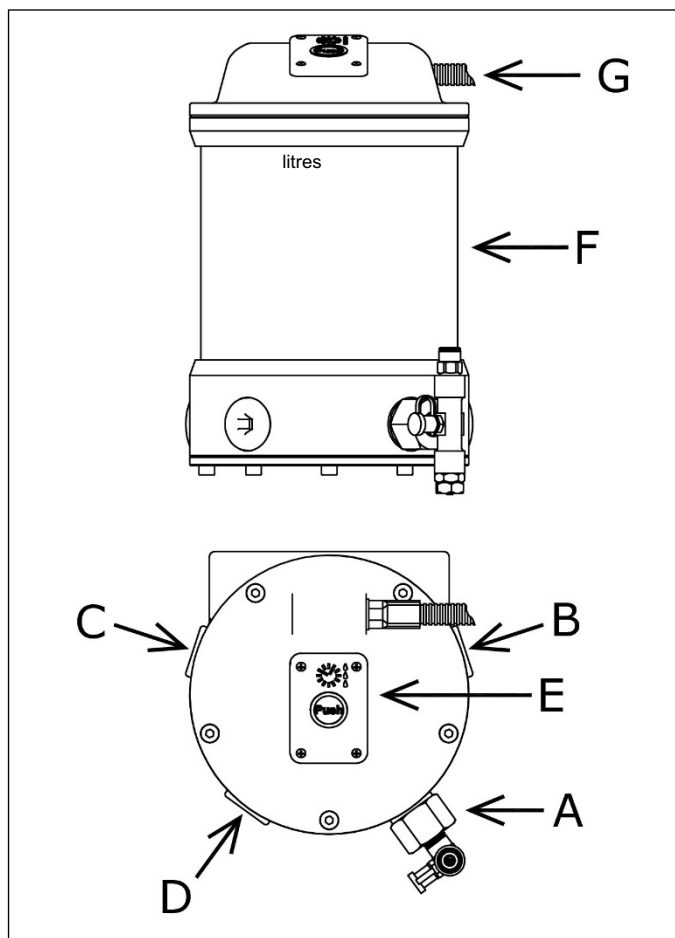

Figure 5

The Model K electric pump is a piston-type pump driven by an eccentric mechanism. It is designed for grease lubrication and can be equipped with up to three pumping elements connected to the centralized lubrication system. Each pumping element can be installed on one of the four designated outlets (Figure 5, ref. A, B, C, D).

One outlet is always reserved for the filling plug, fitted with a grease nipple for filling the reservoir. Compact in design, the pump is manufactured from materials selected to withstand mechanical stress and resist corrosion caused by atmospheric agents.

The reservoir (Figure 5, ref. F) is made of transparent extruded polycarbonate. The reservoir is filled through a dedicated grease nipple installed on the plug of one unused pumping outlet. Adhesive strips applied to the outside of the reservoir allow the minimum and maximum levels to be identified easily.

The reservoir capacity is approximately **1.2 litres**.

A spring-loaded follower plate system keeps the lubricant compacted, ensuring correct operation under all working conditions.

The electric gearmotor is an axial type with a planetary gearbox. It is powered by low-voltage direct current and can be operated by the user either directly or via the programmed settings of the control timer (Figure 5, ref. E).

The Model K electric pump is available in 12–24 V DC versions, with a control system either with or without a programmable timer. Electrical connections are made via wired systems (Figure 5, ref. G).

Table A shows the coding of the available pump versions.

**Table A**

		Without timer	Timer pause/work	
Capacity Tension		1,2 Litres	1,2 Liters	
	12V	180151	180152	Grease
24V	180154	180153		

---

**General Technical Data – Model K Pump**

The general technical data of the Model K pump are listed below:

- Operating temperature: from –30 °C to +80 °C
- Number of outlets: 1, 2, or 3
- Pumping system: Piston type, Ø 4, 6, and 8 mm, driven by an eccentric mechanism
- Main line connection: Quick fitting for Ø 6 mm pipe
- Reservoir capacity: 1.2 litres, with minimum and maximum level indications on the transparent reservoir
- Lubricant: Grease up to **NLGI** consistency grade **#2**
- Reservoir filling: Via grease nipple M10x1 UNI 7663
- Air removal system: Spring-loaded follower plate
- Delivery rate per outlet: See section 1.4.2 “Pumping Element”
- Gearmotor unit: Axial type with planetary gearbox and shielded DC electric motor
  - Rated voltage: 24 V DC / 12 V DC
  - Rated current absorption: 0.5 A (24 V DC) / 1 A (12 V DC)
  - Maximum start-up current: 3 A (24 V DC) / 6.5 A (12 V DC)
  - Speed: 22 rpm
- Electric pump power supply: 12 V DC / 24 V DC
- Degree of protection: IP65
- Control system: **None** or **pause/work timer**

**Table B** shows the empty weight of the pump in the standard configuration, i.e. with one pumping element installed.

**Table B**

Reservoir Capacity	Weight
1,2 liters	3,0 kg

Figure 6 below shows the overall maximum dimensions of the pump, expressed in [mm]:

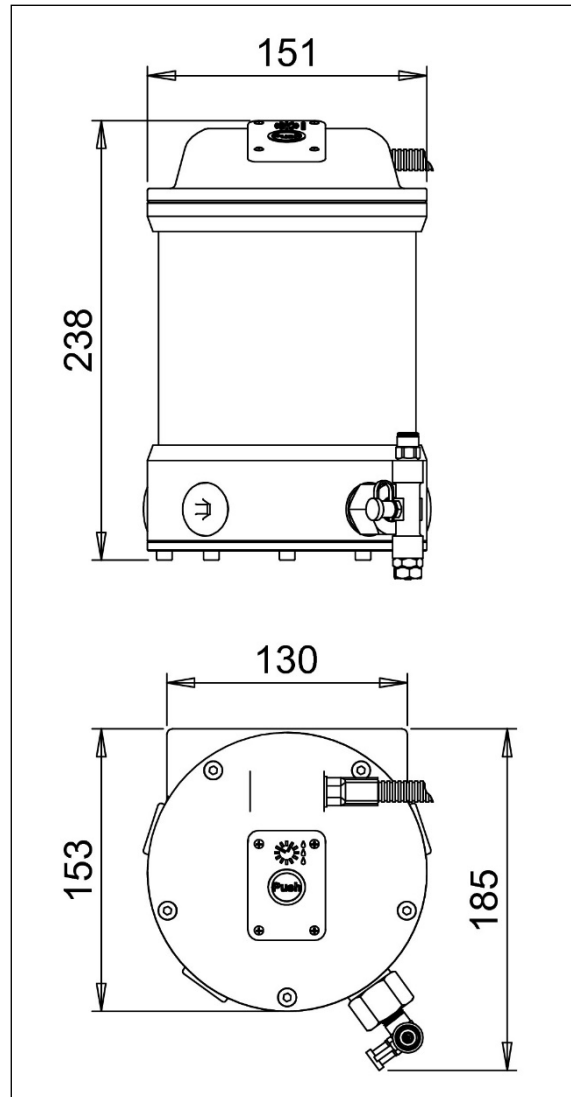

Figure 6

### 1.4.2) TIMER

The timer is located inside the pump housing, in a waterproof area. Its function is to automatically control the centralized lubrication system.

Technical specifications for models with Pause/Operation timer, 24 V DC

Operating voltage:	20–30 V DC
Maximum load current:	5 A
Short-circuit current limit:	7 A
Stand-by current consumption:	30 mA
Current consumption during cycle:	50 mA (motor current excluded)
Operating temperature:	from –25 °C to +70 °C
Storage temperature:	from –30 °C to +80 °C

Hardwareprotections:

- Overload protection
- Reverse polarity protection
- Overtemperature protection
- Overvoltage protection (max. 45 V)

Time memory type:	Digital <b>EEPROM</b>
Memory retention:	Unlimited
Pause time setting range:	5 minutes to 12 hours (digitally programmable)
Operating time setting range:	20 seconds to 8 minutes (digitally programmable)

#### WARNINGS:



- To supply power to the timer, strictly comply with the instructions provided in section 4.1.0) WIRING DIAGRAM.



- Do not supply the timer with voltages above 35 V to prevent malfunctions.

#### ▪ PAUSE-OPERATING CYCLE

The operating cycle is fully controlled by the digital timer programming. Once the programmed pause time has elapsed, the system starts an operating cycle with a duration equal to the programmed operating time.

The operating time must be set so that the lubrication cycle is long enough to supply all bearing points connected to the system.

---

The time required to complete one lubrication cycle can be determined by disconnecting the secondary line from any outlet of the progressive distributor and measuring the time interval between two successive lubricant discharges.





If you have difficulty determining the operating time, please contact **Customer Service**

### 1.5.0) STORAGE

The centralized lubrication system is usually supplied disassembled to customers.

Before forwarding the system, **CIAPONI LUBRIFICAZIONE CENTRALIZZATA s.r.l.** adopts all the necessary measures to guarantee a correct packaging of all the components.







-  • The user shall be responsible for storing all the components received by **CIAPONI LUBRIFICAZIONE CENTRALIZZATA s.r.l.**, indoors, in clean and dry rooms and at a safety distance from chemical and/or corrosive substances.
-  • **CIAPONI LUBRIFICAZIONE CENTRALIZZATA s.r.l.** shall not be responsible for damages originating from the incorrect storage of the components described.
-  • It is useful to remember that the user is fully responsible for a safe loading, unloading and handling of the system.

### 1.6.0) ASSEMBLY

The operating procedure that follows describes the operations that have to be carried out to assemble the centralized lubrication system.

For information on overall dimensions, weights and technical specifications of the single components, see Chapter 1.4.0) *TECHNICAL DATA*.

It is also useful to remember that:

-  • These operations must always be performed by trained and qualified technicians.
-  • The protection and safety devices fitted on the vehicle or machine should not be modified or disabled. These devices may be removed during the installation of the system but must be reinstalled after the installation has been completed.
-  • All centralized lubrication systems must be installed away from heat sources.
-  • Centralized lubrication systems should not be installed in particularly aggressive environments with chemicals that could potentially damage the components of the system.
-  • Welding and/or drilling operations required to install the centralized lubrication system must be performed in compliance with the technical specifications of the vehicle or machine manufacturer.
-  • Lubrication systems must be fitted only with the accessories supplied or certified by the Manufacturer.

### 1.6.1) OPERATING PROCEDURE

F	Activity
0	Remove all the components of the system from the package.
1	Visually inspect all the components of the system in order to detect potential damages originating from transportation or from an improper storage.
	All damages should be promptly reported to the <b>Customer Service</b> of <b>CIAPONI LUBRIFICAZIONE CENTRALIZZATA S.r.l.</b>



F

Activity

- *ELECTROPUMP*

2

**The following recommendations should be observed:**

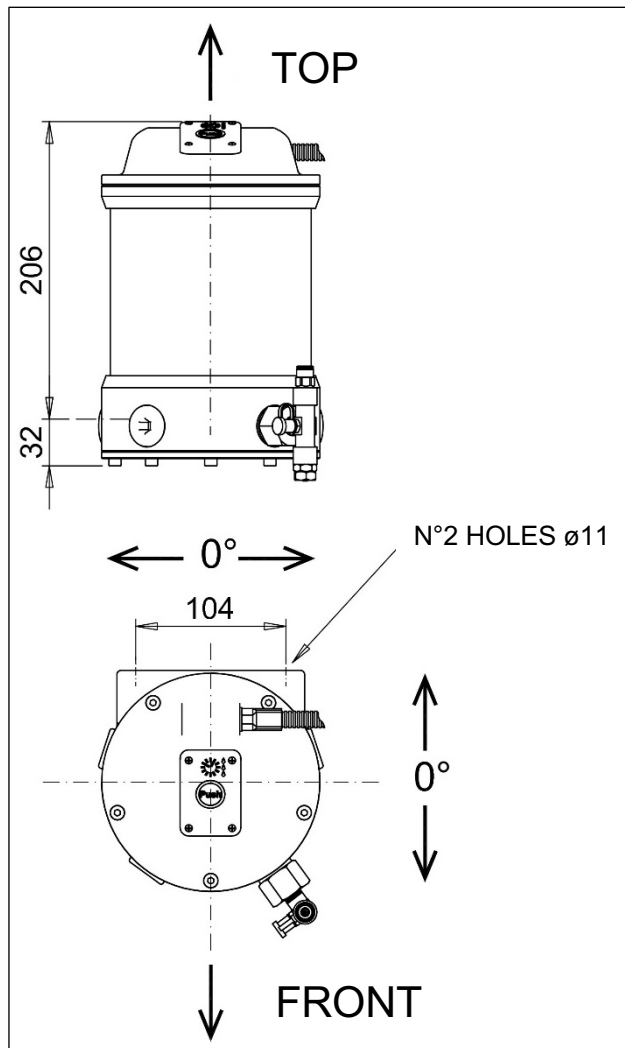

**Do not** install the electric pump in liquids or on supports subject to strong vibration.

**Do not** install the pump near heat sources or close to electrical equipment that could affect the correct operation of the control timer.

**Do not** install the pump in areas containing explosive or flammable mixtures.

Position the Model K electric pump as shown in the figure.

**Maintain** a minimum clearance of 100 mm from surrounding equipment or obstacles that may prevent access to the pump.

**Install** the pump ensuring that the grease nipple for reservoir filling and the control timer are easily accessible.

**Secure** the pump to its support using the  $\varnothing$  11 mm mounting holes and two M8 UNI 5931 - 8.8 screws.

**NOTE:** The pump can also be installed using the **UNIVERSAL BRACKET**, code **00610**, supplied with fixing kit.

F	Activity
	<ul style="list-style-type: none"> <li>• <i>PUMPING ELEMENT</i></li> </ul>
<p>3</p>	<p>The system is normally supplied with one pumping element installed in outlet No. 2.</p> <p>The figure shows the sequence of operations to be carried out if a pumping element must be installed in one of the other available outlets.</p> <ul style="list-style-type: none"> <li>• Unscrew and remove the plug with seal "A" from the outlet where the pumping element is to be installed.</li> <li>• Insert and screw in the pumping element in the selected configuration "B", complete with sealing washer.</li> <li>• Tighten the pumping element to a tightening torque of <b>20 Nm</b>.</li> </ul> <p><b>WARNING:</b> Depending on the position of the drive cam, it may be difficult to screw in the pumping element. In this case, install the pumping element in one of the other outlets, or carefully insert it, ensuring proper thread engagement.</p>
	<ul style="list-style-type: none"> <li>• <i>FITTINGS</i></li> </ul>
<p>4</p>	<p>Remove the grease nipples from the bearing points that are to be lubricated by the automatic system.</p>
<p>5</p>	<p>Screw the selected fittings into the bearing points</p> <p><b>NOTE:</b> If there are difficulties due to limited space when positioning the fittings correctly on the bearing points, use extension fittings.</p>
<p>6</p>	<p>Screw the fittings onto the distributor outlets to be used</p> <p><b>NOTE:</b> The distributor is normally supplied without the screw plugs on the outlets of the metering elements to be used; otherwise, remove the screw plugs.</p>
<p>7</p>	<p>Screw the inlet fitting into the distributor, to which the main line will be connected</p>

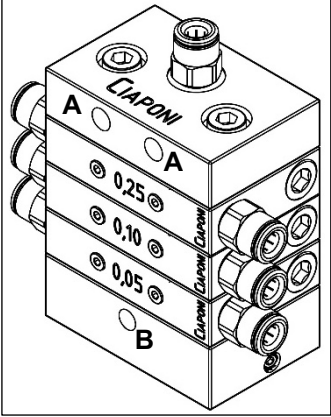
F	Activity
	<ul style="list-style-type: none"> <li>• <i>DISTRIBUTOR</i></li> </ul>
8	<p>Position the distributor, maintaining a minimum clearance of 50 mm from surrounding equipment or obstacles that could hinder easy access to the pipe connection fittings. For the version with sensor, position the distributor so that its wiring can be easily connected to the electric pump. Secure the distributor to the frame or cross members in a position that allows easy access to the bearing points to be lubricated. To fasten the progressive distributor to its support, use the designated holes "A" and "B" located on the first and last elements of the assembled distributor, together with n°3 standard M6 screws.</p> 
	<ul style="list-style-type: none"> <li>• <i>MAIN LINE AND SECONDARY LINE</i></li> </ul>
9	<p>Cut the pipes to the required length with a square (90°) cut: use a shear-type pipe cutter.</p> <p><b>NOTE:</b> When determining the pipe length, consider the minimum bending radius and allow extra length for pipes connected to moving parts.</p>
10	<p>Secure the main line and secondary lines using standard clips or cable ties.</p> <p><b>WARNING:</b> Do not secure or route the pipes along vehicle or machine components subject to heating (e.g. exhaust pipes, engine, etc).</p>
11	<p>Connect the pipes to the corresponding fittings.</p> <p><b>NOTE:</b> The main line connects the pump to the distributor. The secondary lines connect the metering elements to the bearing points to be lubricated.</p>

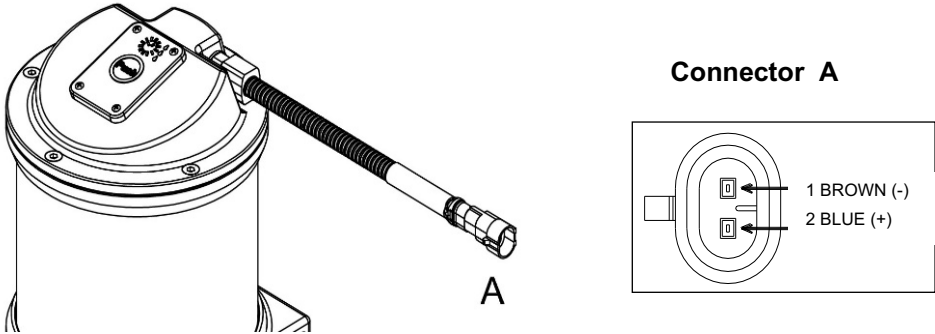
F	Activity
	<ul style="list-style-type: none"> <li>• 12/24 V DC ELECTRICAL CONNECTION</li> </ul>
	<ul style="list-style-type: none"> <li>• VERSION WITHOUT OR WITH TIMER</li> </ul>
13	 <p>The only connection provided is the electrical power supply connection "A". The figure shows the <b>2P power/sensor wiring harness</b>, code <b>150050</b>, used for the connection.</p>

1.6.2) WIRING DIAGRAM VERSION 24 V DC

- VERSION WITH TIMER PAUSE/OPERATION

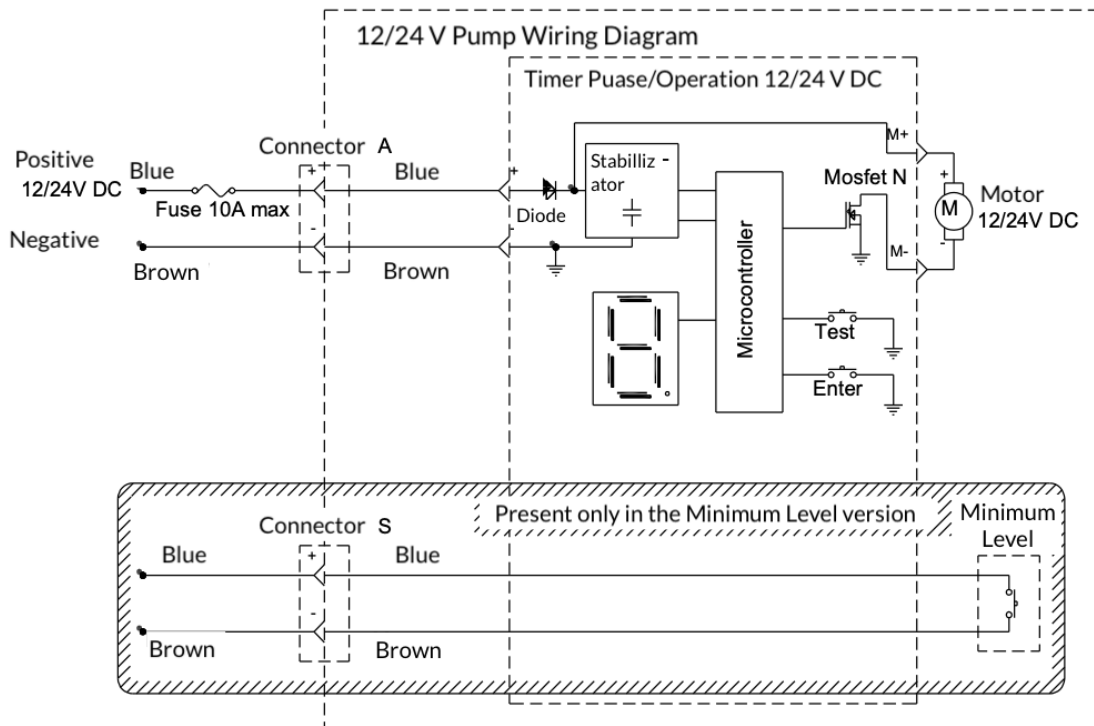

---

## PART 2 – OPERATING MANUAL

### 2.1.0) COMANDS

The table that follows describes the command-and-control devices of centralized lubrication systems with Pause/Operation timer and Pause/Sensor timer.

The figure shows the devices installed on the Timer.

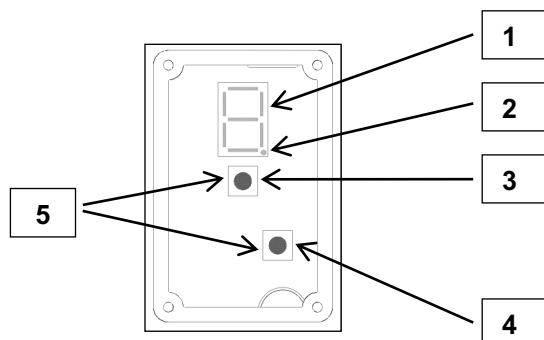

The pump of versions without timer are electrically powered by the system that drives them. In this case, start and control instructions are described along with the management and control instructions of the machine where the system is installed.

Pos	Type	Description
1	Display	<ul style="list-style-type: none"> <li>It displays the parameters that have been set during the time setting procedure.</li> <li>The display LEDs turn on in sequence during ordinary operation.</li> </ul>
2	Led display	This LED turns on when the lubrication system is electrically powered.
3	Button TEST	<p>To access the timer, it is sufficient to slightly press it next to "Push".</p> <p>If it is pressed during ordinary operation, it starts the set working cycle after performing a self-diagnostic check. At the end of the working cycle, the timer returns to the Automatic mode.</p> <p>If it is pressed during the timer programming, it enables to scroll the options.</p>
4	Button ENTER	<ul style="list-style-type: none"> <li>If it is pressed for 3 seconds, it starts the digital programming procedure.</li> <li>If it is pressed briefly during the programming mode, it enables to change the L (working) values.</li> </ul>

## 2.2.0) TIMER PROGRAMMING

The sections that follow summarize the operations that need to be performed to digitally program the control timer.

It is useful to remember that if a power outage occurs, the timer saves the internal data in a digital memory that has no expiry. As soon as power is restored, the timer reloads the saved data and starts counting the time from the point and status in which it had interrupted its operation.

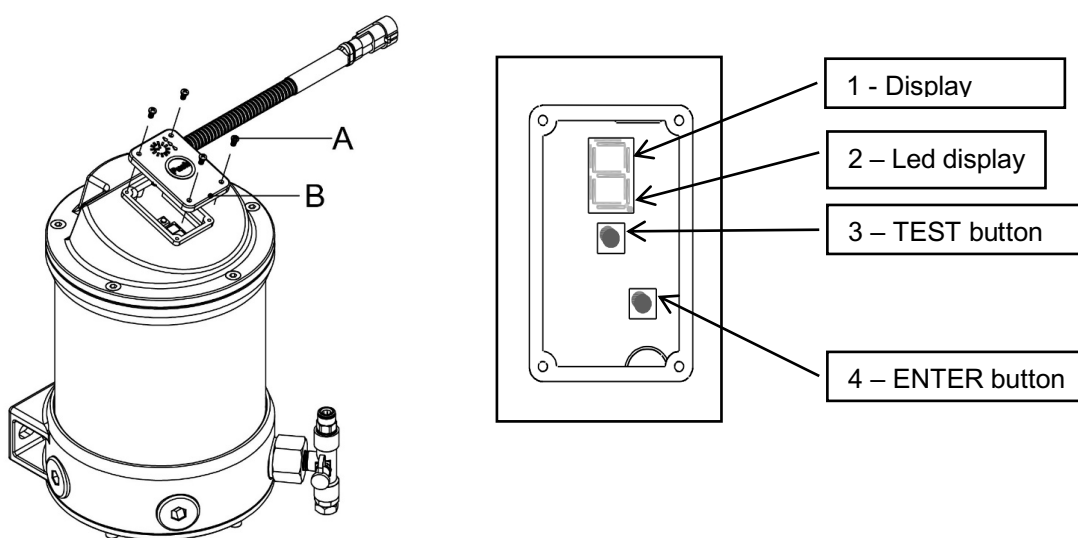

N°	Activity	Consequence
01	Unscrew the fixing screws 'A' and remove the cover 'B' to access the timer	This operation gives access to the timer for digital programming.
02	Press <b>ENTER</b> for 3 seconds	The display turns on and shows letter <b>P</b> (Pause).
03	Briefly press <b>ENTER</b>	The display shows the value set for parameter <b>P</b> .
04	Press <b>TEST</b> to change the value of parameter <b>P</b>	Every time the button is pressed, the display shows in sequence the digits and letters of the pause time settings shown in the table.
05	Briefly press <b>ENTER</b> to confirm the setting	The displayed value is stored as current value for parameter <b>P</b> and the display shows once more letter <b>P</b> .
<p><b>NOTE:</b> For versions with pause-sensor control timer, proceed directly to operation No. 10, as the only parameter that can be set is the pause time (P)</p>		
06	Press <b>TEST</b> to alternate the display of parameters <b>P</b> and <b>L</b>	<p>The display shows letter <b>L</b> (operating time).</p> <ul style="list-style-type: none"> <li><b>NB:</b> it is useful to remember that <b>TEST</b> enables to alternate the display of letters <b>P</b> or <b>L</b>.</li> </ul>

N°	Activity	Consequence
07	Press the button <b>ENTER</b> briefly	The display shows the set value for parameter <b>L</b> .
08	Pressing the <b>TEST</b> button changes the value of parameter <b>L</b>	Each time the button is pressed, the display sequentially shows the digits or letters listed in the operating time setting table.
09	Briefly press the <b>ENTER</b> button to confirm the selected setting	The value shown on the display is stored as the current value of parameter <b>L</b> , and the display shows the letter ' <b>L</b> ' again.
10	Press and hold the <b>ENTER</b> button for 3 seconds	The display turns off and is ready to run with the new set parameters.
11	Reinstall the cover <b>B</b> to access the timer and retighten the fixing screws <b>A</b> .	The pump is ready for operation.



**WARNING** – The electric pump in the version with control timer is supplied with the following default settings:

- Pause time (**P**) = **8**
- Operating time (**L**) = **2**

#### TABLE WITH TIME SETTINGS

• <b>PAUSE:</b> Pause time setting (P)	
Display	Time
<b>0</b>	5 min
<b>1</b>	10 min
<b>2</b>	15 min
<b>3</b>	30 min
<b>4</b>	1 h
<b>5</b>	2 h
<b>6</b>	3 h
<b>7</b>	4 h
<b>8</b>	5 h
<b>9</b>	6 h
<b>A</b>	7 h
<b>B</b>	8 h
<b>C</b>	9 h
<b>D</b>	10 h
<b>E</b>	11 h
<b>F</b>	12 h

• <b>OPERATING:</b> Operating time setting (L)	
Display	Time
<b>0</b>	20 sec
<b>1</b>	40 sec
<b>2</b>	1 min
<b>3</b>	1.5 min
<b>4</b>	2 min
<b>5</b>	2.5 min
<b>6</b>	3 min
<b>7</b>	3.5 min
<b>8</b>	4 min
<b>9</b>	4.5 min
<b>A</b>	5 min
<b>B</b>	5.5 min
<b>C</b>	6 min
<b>D</b>	6.5 min
<b>E</b>	7 min
<b>F</b>	8 min

### 2.3.0) RESERVOIR FILLING

The pump reservoir is filled through the grease nipple located on the plug of a pumping outlet. Remove the cap from the grease nipple and, using a suitable dispensing device, fill the reservoir up to the maximum level (**MAX**) indicated by the adhesive strip on the reservoir. For the characteristics of the lubricant to be used, refer to the following section.

During reservoir filling, the air contained inside is discharged through the designated vent. Ensure that the vent, located at the rear of the reservoir, is not obstructed.

### 2.3.1) LUBRICANTS



- It is useful to remember that systems manufactured by **CIAPONI LUBRIFICAZIONE CENTRALIZZATA s.r.l.** are designed to be used with lubrications with a maximum grade of **NLGI 2**.



- Use only compatible lubricants with **NBR** gaskets.



- CIAPONI LUBRIFICAZIONE CENTRALIZZATA s.r.l.** supplies the system components that are already lubricated with **NLGI 2** lubricant.

FAMILY DESCRIPTION	NLGI GRADE	ASTM PENETRATION AT 25°C IN 1/10 OF MM
Fluid greases	000	445 - 475
Semi-fluid greases	00	400 - 430
Semi-fluid greases	0	355 - 385
Mild greases	1	310 - 340
Medium greases	2	265 - 295

The table provides comparative data between NLGI (National Lubricating Grease Institute) and ASTM (American Society for Testing and Materials) data only of the ranges used by the systems manufactured by **CIAPONI LUBRIFICAZIONE CENTRALIZZATA s.r.l.**

For further information on technical data and safety measures, see the **Product Safety Sheet** (Directive **93/112/EEC**) related to the type of lubricant selected or supplied by the manufacturer.

### 2.4.0) START-UP

The operating procedure described below briefly describes the operations that must be performed to start the system.



**NB:** The following procedure should always be performed when:

- During the initial start-up following installation
- After every maintenance operation
- If the system has not been in operation for a considerable amount of time

#### 2.4.1) OPERATING PROCEDURE

N°	Activity	Consequence
Make sure that: <ul style="list-style-type: none"> <li>• All the operations described in Chapter 1.6.0) ASSEMBLY have been performed</li> <li>• All the Pause and Pause/Operation times have been set (for versions with control timer)</li> <li>• The lubricant level in the pump tank is above the minimum level</li> </ul>		
0	Disconnect one or more secondary pipes from the bearing lubrication points	Verify that the lubricant reaches the bearing.
1	Press the manual Start button (TEST)	The pump performs one cycle.
2	Repeat the operation described above until the lubricant reaches all the lubrication points of the bearings from which the pipes have been disconnected	The lubricant dispensing system is running correctly.
3	Reconnect the pipes to the bearing lubrication points	The system is set in Automatic mode.



- **WARNING:** if the system is not operating correctly, see Chapter 3.3.0) ANOMALIES

## PART 3 – MAINTENANCE INSTRUCTION

### 3.1.0) MAINTENANCE INSTRUCTION

This paragraph provides essential information to allow maintenance technicians to perform ordinary maintenance operation in full safety

Before performing any maintenance operation, operators should remember to:

• Verify	That the system is not running
• Check	That the electro-pump has been disconnected from the power supply
• Check	That the disconnection switch upstream from the electric cubicle has been disconnected
• Adopt	All the measures referred to in current accident prevention laws and specifically those necessary to signal that servicing operations are in progress.

### 3.2.0) SCHEDULED MAINTENANCE

Due to simplicity of design, robustness and reliability of the components used, **CIAPONI LUBRIFICAZIONE CENTRALIZZATA S.r.l.** recommends only a limited number of inspections and scheduled maintenance operations.

The table that follows lists the checks that have to be performed periodically, along with the frequency and type of operation that the technician must perform to guarantee the efficiency of the system in time.

VERIFICA	FREQUENZA	INTERVENTO
Tightening of components	After the first 500 hours	Check that all components have been correctly tightened.
Pipe fixing	After the first 500 hours Every 1500 hours	Check that the fittings have been installed Check that machine parts have been correctly installed
Operation of the electro-pump	Every 6 months	Check the operation of the electro-pump with button Test
Filling filter	Every two refills	Check and, if necessary, replace (see the following section).

---

### 3.2.1) FILTER REPLACEMENT (GREASE VERSIONS ONLY)

To service the reservoir filling filter, remove the grease nipple and the filter.  
Check the condition of the filter and, if necessary, clean it using compressed air.  
If, after cleaning, the filter is still dirty, replace it.  
Then reinstall the filter and the grease nipple.  
Tighten the grease nipple to a maximum tightening torque of **6 Nm**.

### 3.3.0) ANOMALIES

In this chapter, maintenance personnel are provided with:

- **possible malfunctions that may occur during system operation;**
- **the causes that may lead to system start-up failure or shutdown;**
- **the corrective actions to be taken, where applicable.**

**NOTE:** The lubrication system with **pause-sensor control timer** is equipped with an illuminated remote monitoring button. If, after a normal operating cycle, the button remains steadily lit, this indicates that:

- the grease level in the reservoir has reached the minimum level; or
- a system malfunction has occurred.

In any case, the timer stops system operation 10 minutes after activation.

<b>Nr</b>	<b>Anomaly</b>	<b>Cod.</b>	<b>Causa</b>	<b>Remedy to adopt</b>
01	The pump motor doesn't work	01.01	No power supply	Check the power supply and the status of the fuse.
		01.02	The electronic card is not working	Replace the electronic card.
		01.03	The reduction gear doesn't work	Replace the reduction gear.
02	The pump doesn't delivery lubricant	02.01	The reservoir is empty	Fill the reservoir with clean lubricant.
		02.02	Air bubbles in lubricant	Disconnect the main line from the fitting connected to the pumping element. Operate the pump in manual mode until lubricant flows out of the fitting completely free of air bubbles.
		02.03	Unsuitable lubricant	Replace the lubricant with a suitable one
		02.04	Pumping unit element blocked	Disassemble the pumping element and clean the suction ducts
		02.05	The pumping element piston is worn	Replace the pumping unit
		02.06	The delivery valve of the pumping unit is blocked	Replace the pumping unit
03	The pump runs, but no lubricant reaches the bearing lubrication points	03.01	Disconnect pipes	Check the status of the pipes and the connections to fittings. Replace worn pipes.
		03.02	Progressive distributor blocked.	Replace or clean the distributor.
04	The lubricant is distributed to the bearing points in irregular quantities	04.01	The distributor is not correctly connected to the bearing points	Check the metering configuration against the system layout diagram.
		04.02	Incorrect pause time setting.	
05	The display LED is not lit	05.01	The power supply voltage is incorrect	Check that the power supply voltage is between 20 V DC and 30 V DC, and take appropriate action on the power supply circuit
06	The motor doesn't start when TEST is pressed	06.01	The motor is not correctly connected to the timer	Check the cables that connect the electric motor to the timer and restore connections.
		06.02	The motor is not working correctly	Check that the motor is not short-circuited and that it does not absorb a current above 7A. Replace the reduction gear.
07	The display LEDs alternate but the motor doesn't run	07.01	Faulty motor	Contact the Customer Service.
08	The pump starts the greasing phase but doesn't complete it immediately	08.01	Faulty motor or high output absorption	Allow the pump to cool down for a few minutes and retry. If the problem reoccurs, contact the Customer Service.

**PART 4 – SPARE PARTS**

The block diagram shown below provides the key for interpreting the spare parts identification tables.

- **WARNING:** to require the provision of spare parts necessary to specify, in addition to the code of the particular request, the serial number of the system used and the version number, obtainable from the nameplate for CE marking, as shown in the figure.

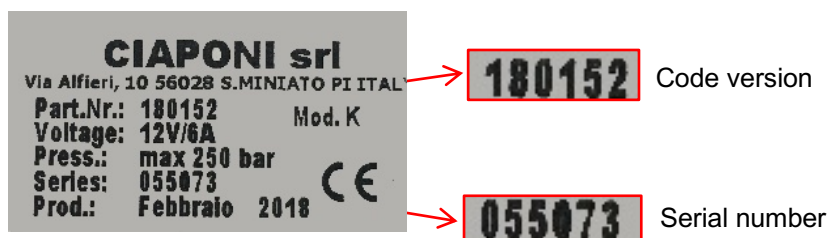

# MAIN CAUSES OF MACHINE DOWNTIME

## WITHOUT CIAPONI CENTRALISED LUBRICATION

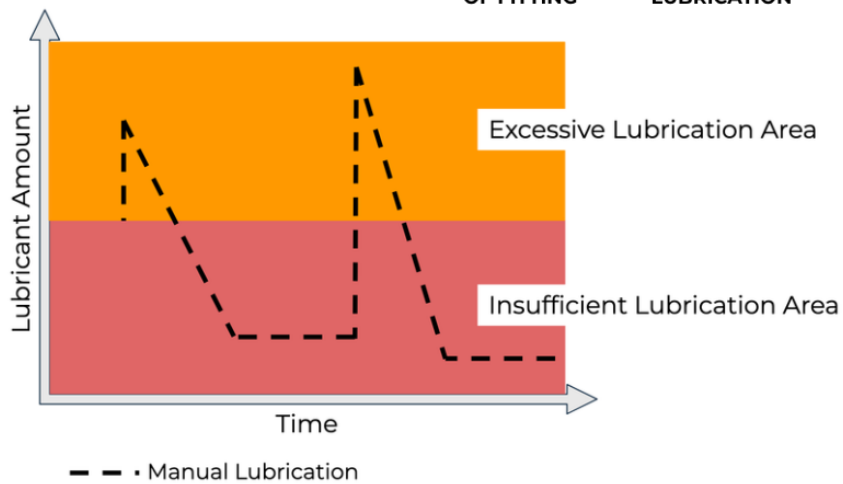
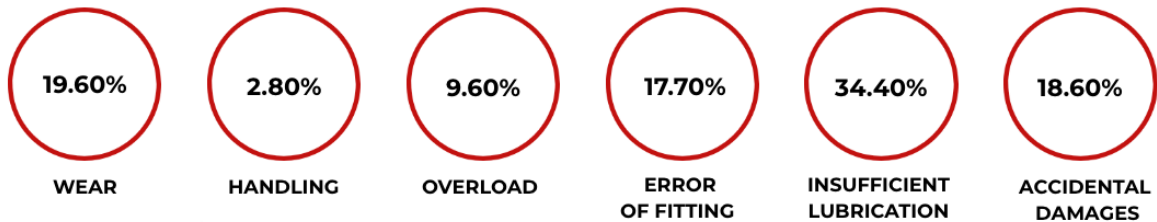

## WITH CIAPONI CENTRALISED LUBRICATION

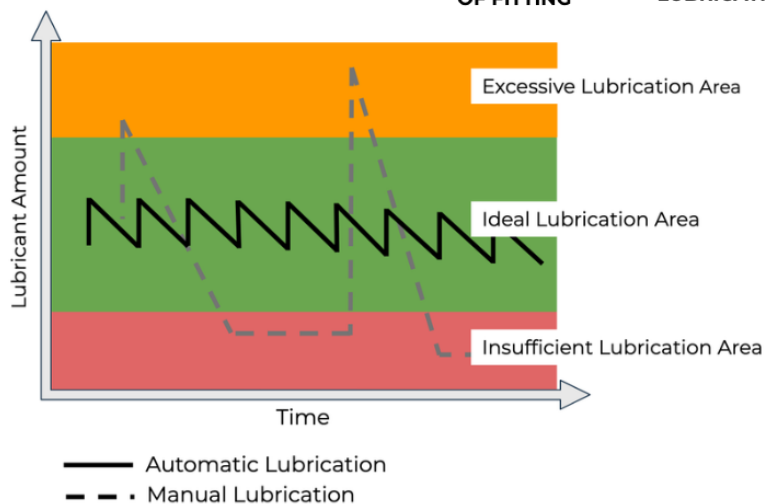
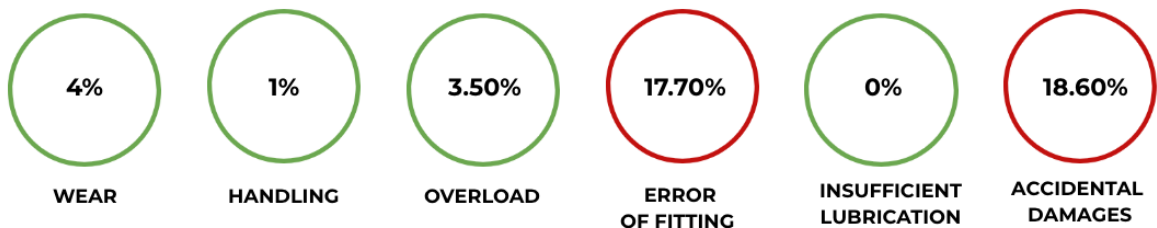



Headquarters: Guerrazzi Street, 113  
56028 S. Miniato Basso (PI) - ITALY  
Tel. 0039 0571 42661 – Fax 0039 0571 42244  
Web site: [ciaponilube.com](http://ciaponilube.com)  
E-mail address: [export@ciaponilube.com](mailto:export@ciaponilube.com)  
Cod. Fis. / Partita I.V.A. n° IT01160480503

